

- / octangular 4.5 m
- / foldable
- / walk-in cold store
- / longitudinal draft counters
- / 3 open-up sales flaps

4500/8 K/LB



Bar and Event Trailer

# 4500/8 K/LB

## Handling

Opening/closing 1 person app. 10 min.

## Weights

Gross vehicle weight max.	3.350 kg
Tare weight basic type app.	2.400 kg
Payload basic type app.	950 kg

## Dimensions

Overall (without roof display) app.	6.620 x 2.550 x 2.900 mm
Octagonal sales area app.	3.250 x 3.950 mm
Interior standing height app.	2.260 mm
Covered sales area app.	5.950 x 6.200 mm
Cold store interior app.	1.120 x 2.050 x 2.100 mm
Surrounding counter length (3 sides) app.	16.800 mm
Longitudinal draft counter app.	2.200 x 650 mm

## Standard features

hot galvanized chassis with single axle, height adjustable drawbar, EU standard overrunning and parking brake, 12 V EU standard lighting system, reinforced jockey wheel and support legs, stainless steel corner posts, bodywork hot galvanized covered with aluminum sheets, entrance door at the rear, PEKI Alustar all-aluminum system floor, full insulated cold store with entrance door at the front and passing door to the sales area, 230 V 16 A 50 Hz reinforced cooling machine, PEKI space saving one hand lifting system for the foldable side extensions, PEKI all-aluminum system roof, insulated sandwich roof panel and open-up flaps, surrounding guest counters in rounded design, foldable tables at the rear, reinforced all-aluminum longitudinal draft counters, brushed NCS coverings with sink, cold water tap and drip tray, 230 V 16 A basic electric system with German standard plugs, supply for fresh and used water with connections, PVC corner covers, ...

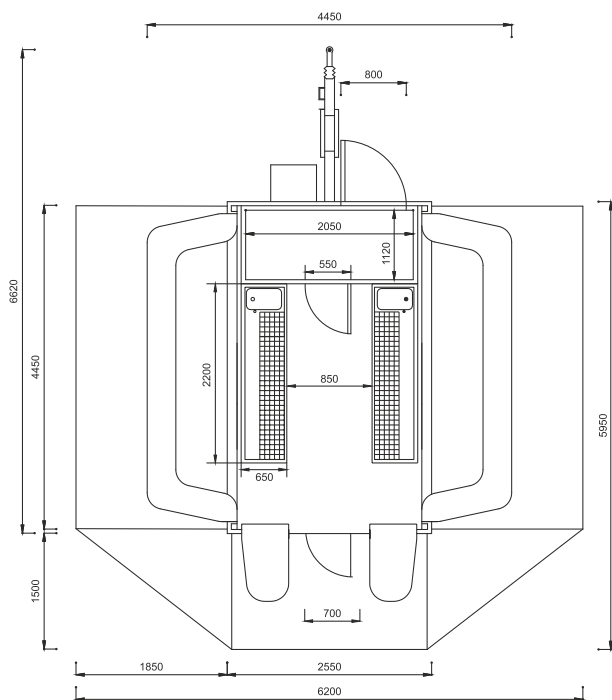

Also available with arched roof. All weights and dimensions are app., in basic version as described above and according DIN 70020. We reserve the right for changes and modifications without prior notice. Pictures show special equipment. Errors and omissions reserved. © PEKI 2023



PEKI GmbH  
Vehicles and Systems for Events  
Am Neuhaus 2  
DE-54317 Osburg/Trier Germany

Phone: +49-6500-9141-0  
Fax: +49-6500-9141-83  
e-mail: info@peki.com  
www.peki.com

